

TSOP, FP-BGA  
Commercial Temp  
Industrial Temp

## 256K x 16 4Mb Asynchronous SRAM

8, 10, 12 ns  
3.3 V  $V_{DD}$   
Center  $V_{DD}$  and  $V_{SS}$

### Features

- Fast access time: 8, 10, 12 ns
- CMOS low power operation: 130/105/95 mA at minimum cycle time
- Single 3.3 V power supply
- All inputs and outputs are TTL-compatible
- Byte control
- Fully static operation
- Industrial Temperature Option:  $-40^{\circ}$  to  $85^{\circ}\text{C}$
- Package line up
  - GP: RoHS-compliant 400 mil, 44-pin TSOP Type II package
  - X: 6 mm x 10 mm Fine Pitch Ball Grid Array package
  - GX: RoHS-compliant 6 mm x 10 mm Fine Pitch Ball Grid Array package
- RoHS-compliant TSOP-II, and FP-BGA packages available

### Description

The GS74116A is a high speed CMOS Static RAM organized as 262,144 words by 16 bits. Static design eliminates the need for external clocks or timing strobes. The GS operates on a single 3.3 V power supply and all inputs and outputs are TTL-compatible. The GS74116A is available in a 6 x 10 mm Fine Pitch BGA package and 400 mil TSOP Type-II packages.

### Pin Descriptions

Symbol	Description
A <sub>0</sub> -A <sub>17</sub>	Address input
DQ <sub>1</sub> -DQ <sub>16</sub>	Data input/output
$\overline{\text{CE}}$	Chip enable input
$\overline{\text{LB}}$	Lower byte enable input (DQ1 to DQ8)
$\overline{\text{UB}}$	Upper byte enable input (DQ9 to DQ16)
$\overline{\text{WE}}$	Write enable input
$\overline{\text{OE}}$	Output enable input
$V_{DD}$	+3.3 V power supply
$V_{SS}$	Ground
NC	No connect

### FP-BGA 256K x 16 Bump Configuration (Package X)

	1	2	3	4	5	6
A	$\overline{\text{LB}}$	$\overline{\text{OE}}$	A0	A1	A2	NC
B	DQ16	$\overline{\text{UB}}$	A3	A4	$\overline{\text{CE}}$	DQ1
C	DQ14	DQ15	A5	A6	DQ2	DQ3
D	VSS	DQ13	A17	A7	DQ4	VDD
E	VDD	DQ12	NC	A16	DQ5	VSS
F	DQ11	DQ10	A8	A9	DQ7	DQ6
G	DQ9	NC	A10	A11	$\overline{\text{WE}}$	DQ8
H	NC	A12	A13	A14	A15	NC

6 x 10 mm Substrate  
Top View

### TSOP-II 256K x 16 Pin Configuration (Package GP)

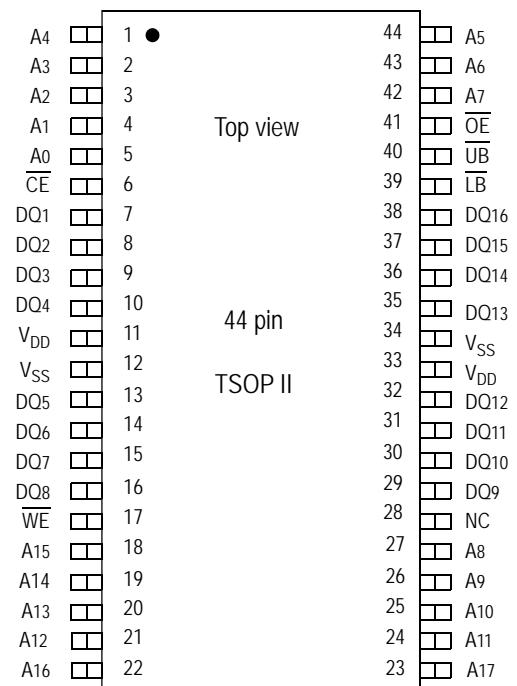

## Block Diagram

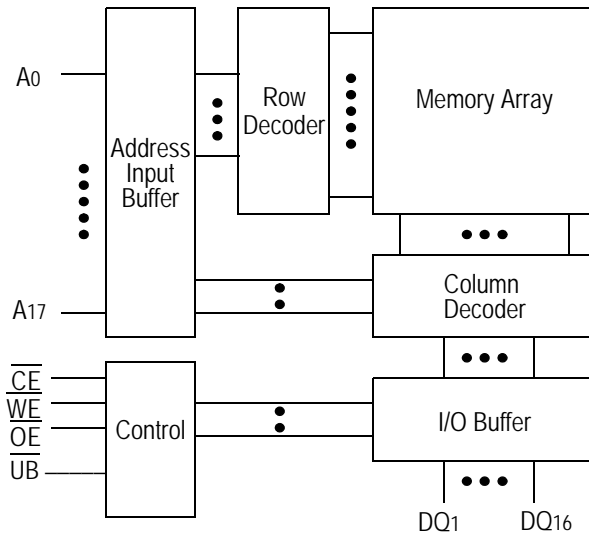

## Truth Table

$\overline{CE}$	$\overline{OE}$	$\overline{WE}$	$\overline{LB}$	$\overline{UB}$	DQ1 to DQ8	DQ9 to DQ16	VDD Current
H	X	X	X	X	Not Selected	Not Selected	ISB1, ISB2
L	L	H	L	L	Read	Read	I <sub>DD</sub>
			L	H	Read	High Z	
			H	L	High Z	Read	
L	X	L	L	L	Write	Write	
			L	H	Write	Not Write, High Z	
			H	L	Not Write, High Z	Write	
L	H	H	X	X	High Z	High Z	
L	X	X	H	H	High Z	High Z	

Note:

X: "H" or "L"

### Absolute Maximum Ratings

Parameter	Symbol	Rating	Unit
Supply Voltage	$V_{DD}$	-0.5 to +4.6	V
Input Voltage	$V_{IN}$	-0.5 to $V_{DD} + 0.5$ ( $\leq 4.6$ V max.)	V
Output Voltage	$V_{OUT}$	-0.5 to $V_{DD} + 0.5$ ( $\leq 4.6$ V max.)	V
Allowable power dissipation	PD	0.7	W
Storage temperature	$T_{STG}$	-55 to 150	$^{\circ}C$

**Note:**

Permanent device damage may occur if Absolute Maximum Ratings are exceeded. Functional operation shall be restricted to Recommended Operating Conditions. Exposure to higher than recommended voltages for extended periods of time could affect device reliability.

### Recommended Operating Conditions

Parameter	Symbol	Min	Typ	Max	Unit
Supply Voltage for -8/-10/-12	$V_{DD}$	3.0	3.3	3.6	V
Input High Voltage	$V_{IH}$	2.0	—	$V_{DD} + 0.3$	V
Input Low Voltage	$V_{IL}$	-0.3	—	0.8	V
Ambient Temperature, Commercial Range	$T_{Ac}$	0	—	70	$^{\circ}C$
Ambient Temperature, Industrial Range	$T_{AI}$	-40	—	85	$^{\circ}C$

**Notes:**

1. Input overshoot voltage should be less than  $V_{DD} + 2$  V and not exceed 20 ns.
2. Input undershoot voltage should be greater than -2 V and not exceed 20 ns.

### Capacitance

Parameter	Symbol	Test Condition	Max	Unit
Input Capacitance	$C_{IN}$	$V_{IN} = 0$ V	5	pF
Output Capacitance	$C_{OUT}$	$V_{OUT} = 0$ V	7	pF

**Notes:**

1. Tested at  $T_A = 25^{\circ}C$ ,  $f = 1$  MHz
2. These parameters are sampled and are not 100% tested.

## DC I/O Pin Characteristics

Parameter	Symbol	Test Conditions	Min	Max
Input Leakage Current	$I_{IL}$	$V_{IN} = 0$ to $V_{DD}$	-1 $\mu$ A	1 $\mu$ A
Output Leakage Current	$I_{LO}$	Output High Z $V_{OUT} = 0$ to $V_{DD}$	-1 $\mu$ A	1 $\mu$ A
Output High Voltage	$V_{OH}$	$I_{OH} = -4$ mA	2.4	—
Output Low Voltage	$V_{OL}$	$I_{LO} = +4$ mA	—	0.4 V

## Power Supply Currents

Parameter	Symbol	Test Conditions	0 to 70°C			-40 to 85°C			Unit
			8 ns	10 ns	12 ns	8 ns	10 ns	12 ns	
Operating Supply Current	$I_{DD}$	$\overline{CE} \leq V_{IL}$ All other inputs $\geq V_{IH}$ or $\leq V_{IL}$ Min. cycle time $I_{OUT} = 0$ mA	130	105	90	140	115	100	mA
Standby Current	$I_{SB1}$	$\overline{CE} \geq V_{IH}$ All other inputs $\geq V_{IH}$ or $\leq V_{IL}$ Min. cycle time	30	25	25	40	35	35	mA
Standby Current	$I_{SB2}$	$\overline{CE} \geq V_{DD} - 0.2V$ All other inputs $\geq V_{DD} - 0.2V$ or $\leq 0.2V$	10			20			mA

## AC Test Conditions

Parameter	Conditions
Input high level	$V_{IH} = 2.4 \text{ V}$
Input low level	$V_{IL} = 0.4 \text{ V}$
Input rise time	$t_r = 1 \text{ V/ns}$
Input fall time	$t_f = 1 \text{ V/ns}$
Input reference level	1.4 V
Output reference level	1.4 V
Output load	Fig. 1 & 2

**Notes:**

1. Include scope and jig capacitance.
2. Test conditions as specified with output loading as shown in Fig. 1 unless otherwise noted.
3. Output load 2 for  $t_{LZ}$ ,  $t_{HZ}$ ,  $t_{OLZ}$  and  $t_{OHZ}$

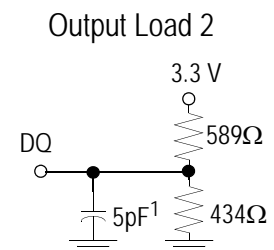
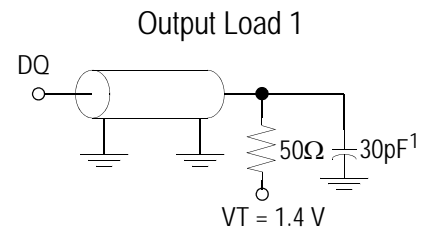

## AC Characteristics

## Read Cycle

Parameter	Symbol	-8		-10		-12		Unit
		Min	Max	Min	Max	Min	Max	
Read cycle time	$t_{RC}$	8	—	10	—	12	—	ns
Address access time	$t_{AA}$	—	8	—	10	—	12	ns
Chip enable access time ( $\overline{CE}$ )	$t_{AC}$	—	8	—	10	—	12	ns
Byte enable access time ( $\overline{UB}$ , $\overline{LB}$ )	$t_{AB}$	—	3.5	—	4	—	5	ns
Output enable to output valid ( $\overline{OE}$ )	$t_{OE}$	—	3.5	—	4	—	5	ns
Output hold from address change	$t_{OH}$	3	—	3	—	3	—	ns
Chip enable to output in low Z ( $\overline{CE}$ )	$t_{LZ}^*$	3	—	3	—	3	—	ns
Output enable to output in low Z ( $\overline{OE}$ )	$t_{OLZ}^*$	0	—	0	—	0	—	ns
Byte enable to output in low Z ( $\overline{UB}$ , $\overline{LB}$ )	$t_{BLZ}^*$	0	—	0	—	0	—	ns
Chip disable to output in High Z ( $\overline{CE}$ )	$t_{HZ}^*$	—	4	—	5	—	6	ns
Output disable to output in High Z ( $\overline{OE}$ )	$t_{OHZ}^*$	—	3.5	—	4	—	5	ns
Byte disable to output in High Z ( $\overline{UB}$ , $\overline{LB}$ )	$t_{BHZ}^*$	—	3.5	—	4	—	5	ns

\* These parameters are sampled and are not 100% tested.

Read Cycle 1:  $\overline{CE} = \overline{OE} = V_{IL}$ ,  $\overline{WE} = V_{IH}$ ,  $\overline{UB}$  and, or  $\overline{LB} = V_{IL}$

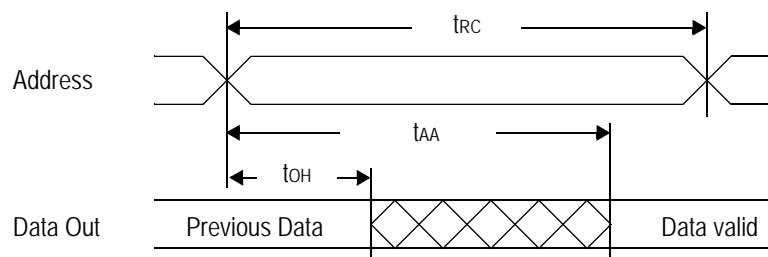

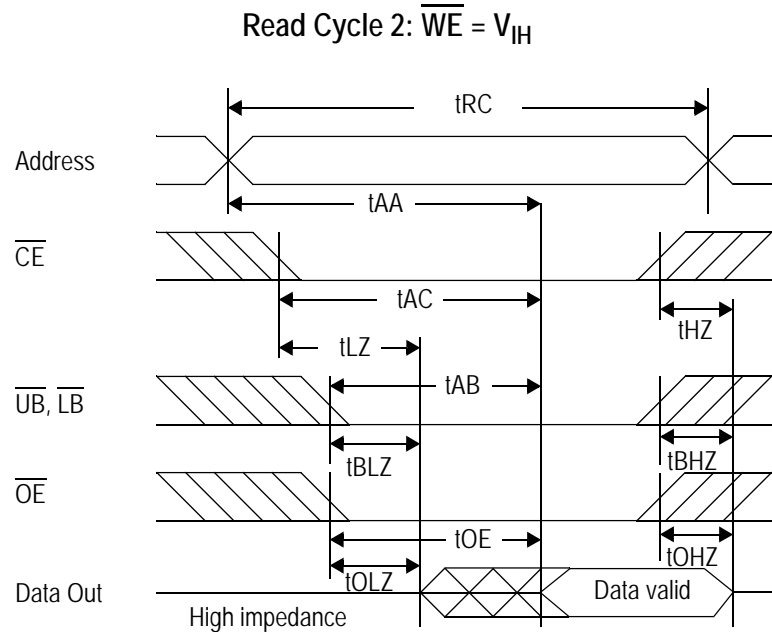

### Write Cycle

Parameter	Symbol	-8		-10		-12		Unit
		Min	Max	Min	Max	Min	Max	
Write cycle time	$t_{WC}$	8	—	10	—	12	—	ns
Address valid to end of write	$t_{AW}$	5.5	—	7	—	8	—	ns
Chip enable to end of write	$t_{CW}$	5.5	—	7	—	8	—	ns
Byte enable to end of write	$t_{BW}$	5.5	—	7	—	8	—	ns
Data set up time	$t_{DW}$	4	—	4.5	—	6	—	ns
Data hold time	$t_{DH}$	0	—	0	—	0	—	ns
Write pulse width	$t_{WP}$	5.5	—	7	—	8	—	ns
Address set up time	$t_{AS}$	0	—	0	—	0	—	ns
Write recovery time ( $\overline{WE}$ )	$t_{WR}$	0	—	0	—	0	—	ns
Write recovery time ( $\overline{CE}$ )	$t_{WR1}$	0	—	0	—	0	—	ns
Output Low Z from end of write	$t_{WLZ}^*$	3	—	3	—	3	—	ns
Write to output in High Z	$t_{WHZ}^*$	—	3.5	—	4	—	5	ns

\* These parameters are sampled and are not 100% tested.

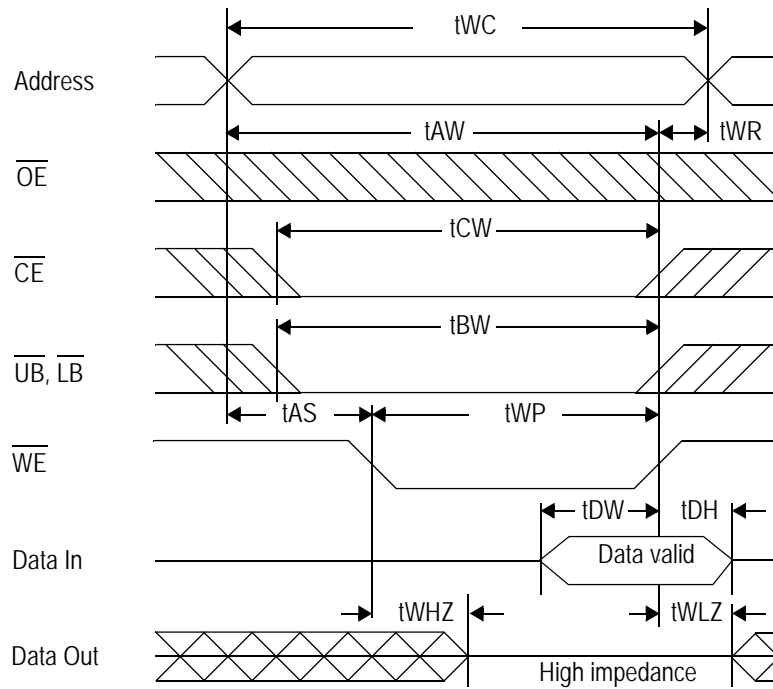
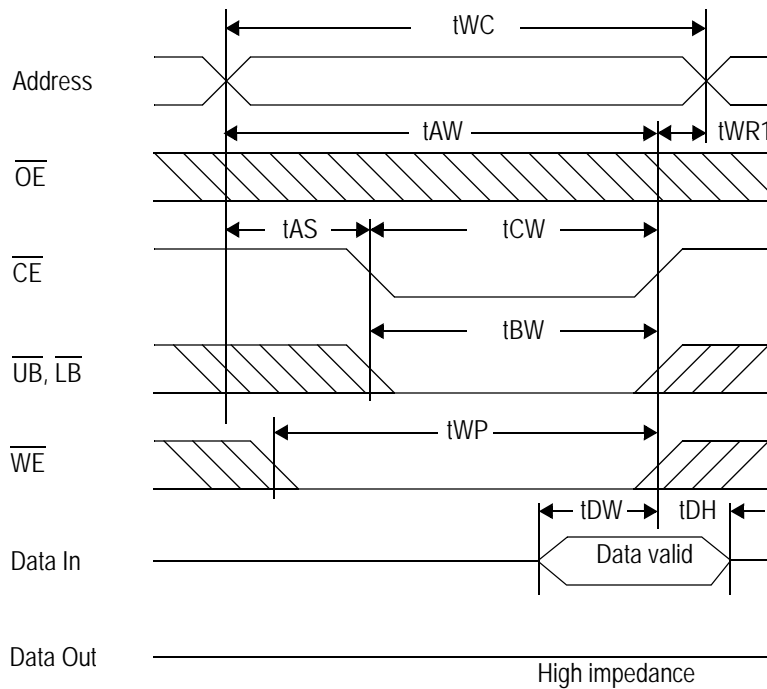
Write Cycle 1:  $\overline{WE}$  control

 Write Cycle 2:  $\overline{CE}$  control

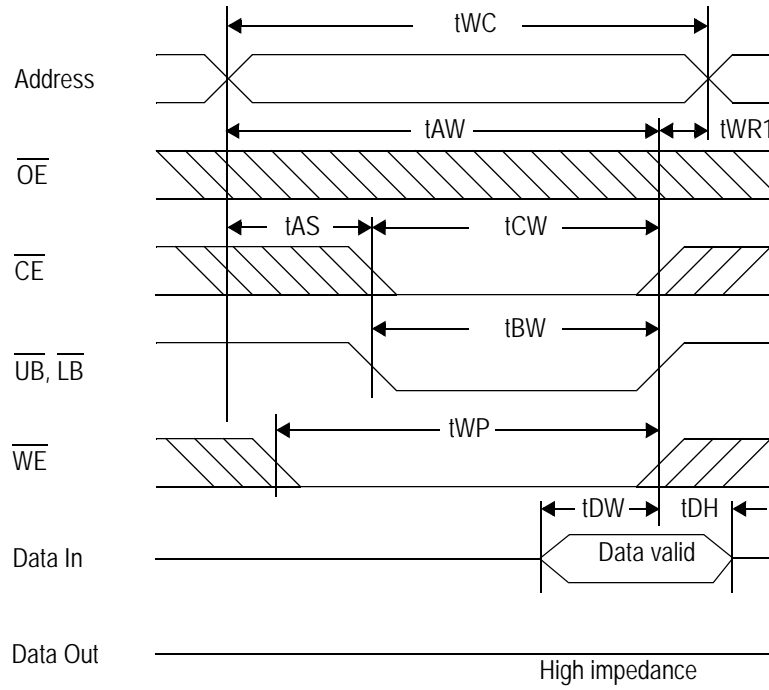
Write Cycle 3:  $\overline{UB}$ ,  $\overline{LB}$  control

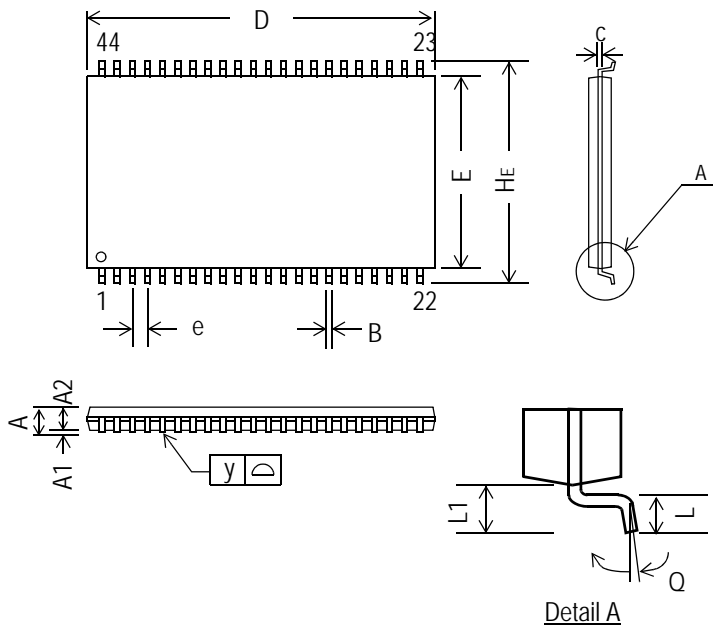

## 44-Pin, 400 mil TSOP-II



Symbol	Dimension in inch			Dimension in mm		
	min	nom	max	min	nom	max
A	—	—	0.047	—	—	1.20
A1	0.002	—	—	0.05	—	—
A2	0.037	0.039	0.041	0.95	1.00	1.05
B	0.01	0.014	0.018	0.25	0.35	0.45
c	—	0.006	—	—	0.15	—
D	0.721	0.725	0.729	18.31	18.41	18.51
E	0.396	0.400	0.404	10.06	10.16	10.26
e	—	0.031	—	—	0.80	—
HE	0.455	0.463	0.471	11.56	11.76	11.96
L	0.016	0.020	0.024	0.40	0.50	0.60
L1	—	0.031	—	—	0.80	—
y	—	—	0.004	—	—	0.10
Q	0°	—	5°	0°	—	5°

**Notes:**

1. Dimension D & E do not include interlead flash.
2. Dimension B does not include dambar protrusion/intrusion.
3. Controlling dimension: mm

## 6 mm x 10 mm FP-BGA

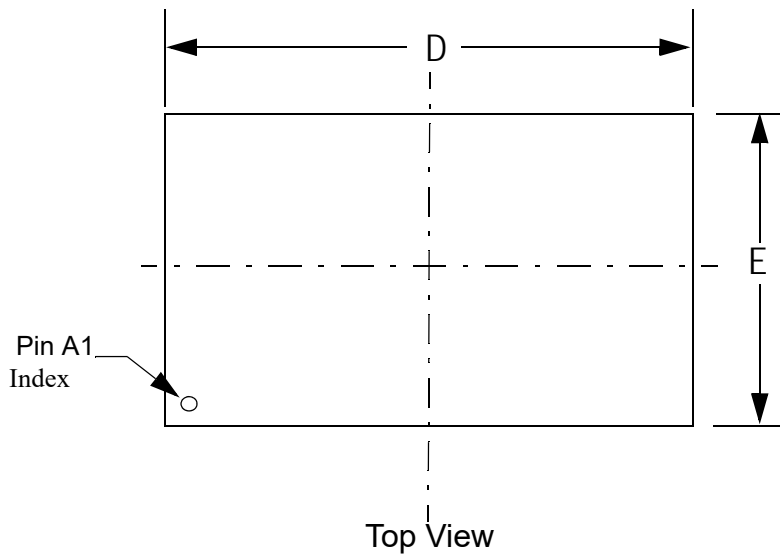

Symbol	Unit: mm
A	1.10±0.10
A1	0.20-0.30
fb	f0.30-0.40
c	0.36(TYP)
D	10.0±0.05
D1	5.25
E	6.0±0.05
E1	3.75
e	0.75(TYP)

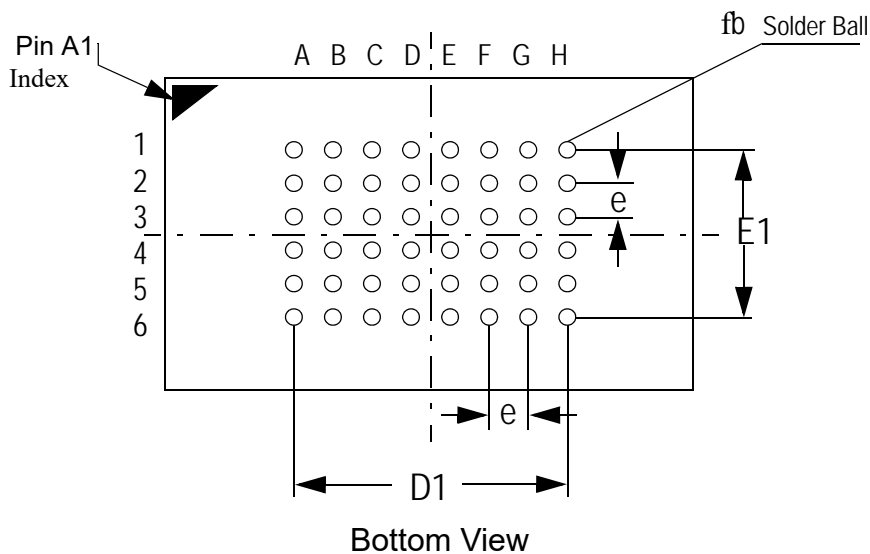
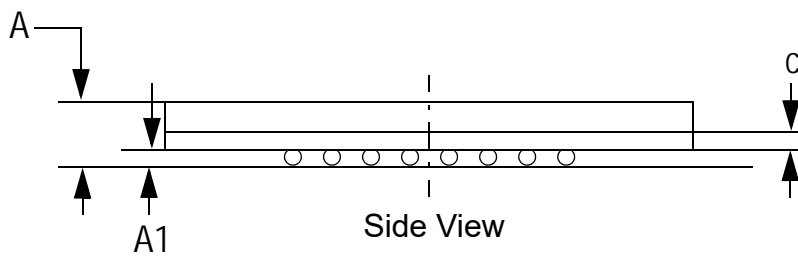

Ordering Information

Part Number *	Package	Access Time	Temp. Range
GS74116AGP-8	RoHS-compliant 400 mil TSOP-II	8 ns	Commercial
GS74116AGP-10	RoHS-compliant 400 mil TSOP-II	10 ns	Commercial
GS74116AGP-12	RoHS-compliant 400 mil TSOP-II	12 ns	Commercial
GS74116AGP-8I	RoHS-compliant 400 mil TSOP-II	8 ns	Industrial
GS74116AGP-10I	RoHS-compliant 400 mil TSOP-II	10 ns	Industrial
GS74116AGP-12I	RoHS-compliant 400 mil TSOP-II	12 ns	Industrial
GS74116AX-8	Fine Pitch BGA	8 ns	Commercial
GS74116AX-10	Fine Pitch BGA	10 ns	Commercial
GS74116AX-12	Fine Pitch BGA	12 ns	Commercial
GS74116AX-8I	Fine Pitch BGA	8 ns	Industrial
GS74116AX-10I	Fine Pitch BGA	10 ns	Industrial
GS74116AX-12I	Fine Pitch BGA	12 ns	Industrial
GS74116AGX-8	RoHS-compliant Fine Pitch BGA	8 ns	Commercial
GS74116AGX-10	RoHS-compliant Fine Pitch BGA	10 ns	Commercial
GS74116AGX-12	RoHS-compliant Fine Pitch BGA	12 ns	Commercial
GS74116AGX-8I	RoHS-compliant Fine Pitch BGA	8 ns	Industrial
GS74116AGX-10I	RoHS-compliant Fine Pitch BGA	10 ns	Industrial
GS74116AGX-12I	RoHS-compliant Fine Pitch BGA	12 ns	Industrial

**Note:**

Customers requiring delivery in Tape and Reel should add the character "T" to the end of the part number. For example: GS74116AGP-8T

## 4Mb Asynchronous Datasheet Revision History

Rev. Code: Old; New	Types of Changes Format or Content	Page #/Revisions/Reason
74116A_r1	Format/Content	• Created new datasheet
74116A_r1; 74116A_r1_01	Content	<ul style="list-style-type: none"> <li>• Added 6 ns and 7 ns speed bins</li> <li>• Updated power numbers</li> <li>• Changed FPBGA package size from 7.2 x 11.65 mm to 6 x 10 mm</li> <li>• Changed package designator from "U" to "X" for FPBGA</li> <li>• Changed D3 on FPBGA pinout to A17 and E3 to NC</li> </ul>
74116A_r1_01; 74116A_r1_02	Content	<ul style="list-style-type: none"> <li>• Updated Recommended Operating Conditions on page 4</li> <li>• Updated Read Cycle and Write Cycle AC Characteristics tables</li> </ul>
74116A_r1_02; 74116A_r1_03	Content	• Removed 6 ns speed bin from entire document
74116A_r1_03; 74116A_r1_04	Content	• Removed 7 ns speed bin from entire document
74116A_r1_04; 74116A_r1_05	Content/Format	<ul style="list-style-type: none"> <li>• Updated format</li> <li>• Added Pb-free information for TSOP</li> </ul>
74116A_r1_05; 74116A_r1_06	Content/Format	• Added Pb-free information for FP-BGA
74116A_r1_06; 74116A_r1_07	Content	<ul style="list-style-type: none"> <li>• Changed Pb-free references to RoHS-compliant</li> <li>• Added RoHS-compliant SOJ part</li> <li>• Added status to Ordering Information table</li> </ul>
74116A_r1_07; 74116A_r1_08	Content	• Removed status from Ordering Information table (all parts MP)
74116A_r1_08; 74116A_r1_09	Content	<ul style="list-style-type: none"> <li>• Removed SOJ references (part is EOL)</li> <li>• (Rev1.09a: Changed 6 x 10 mm Ball Pitch reference on page 1 to 6 x 10 mm Substrate)</li> </ul>
74116A_r1_09; 74116A_r1_10	Content	• Removed TSOP-II 5/6 RoHS-compliant references (part is EOL)
74116A_r1_10; 74116A_r1_11	Content	• Corrected A1 dimension in 6 mm x 10 mm BGA package drawing